

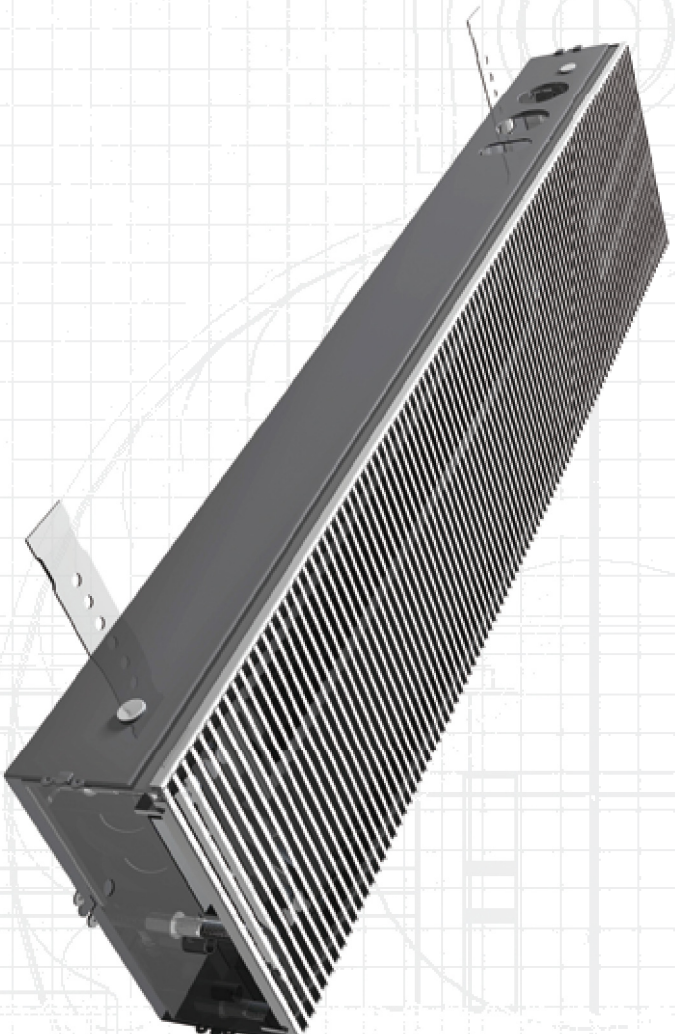

jaga

MICRO CANNAL

Montageanvisning (S) Monteringsanvisning (N)



Komponenter

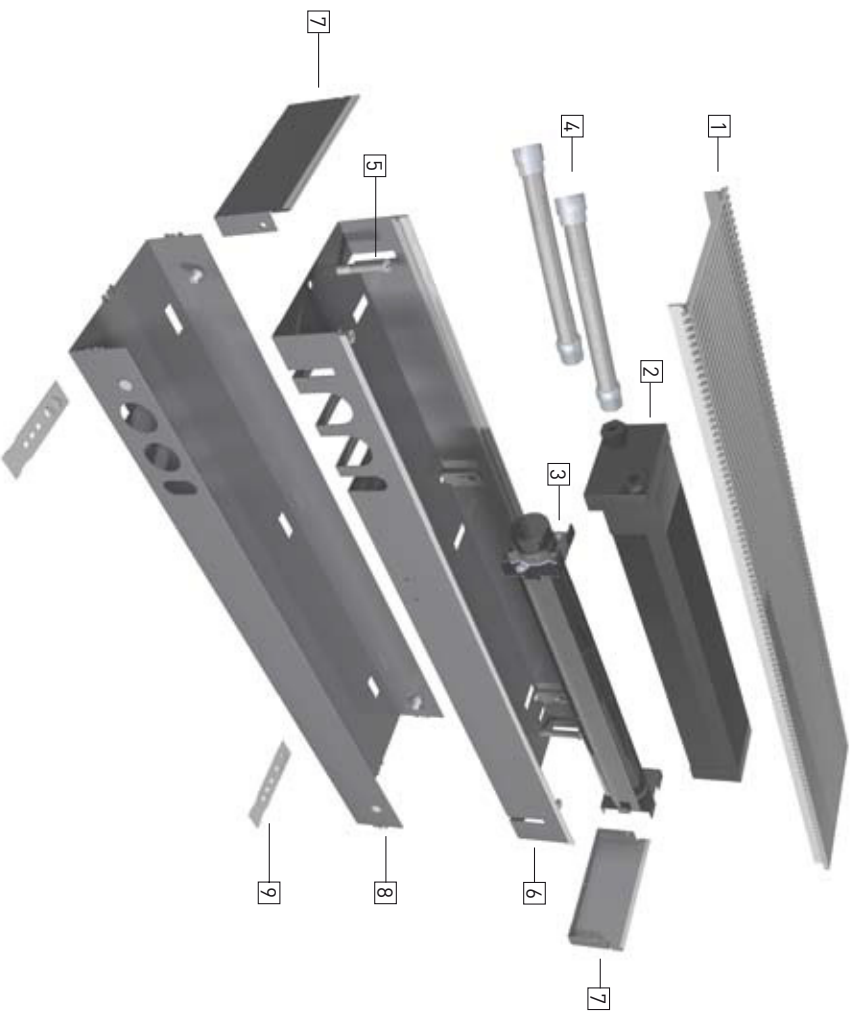

- | | | |
|--|---|---|
| (1) - Galler i rostfritt stål
- Rist i rustfritt stål | (4) - Flexible 15 cm. 1/2"
- Fleksible 15 cm. 1/2" | (7) - Ändedeksel for innerkabinett
- Endedeksel for indre kabinett |
| (2) - Låg H ₂ O värmvekslare
- Lav H ₂ O varmeveksler | (5) - Höjjustering
- Højdejustering | (8) - Ytterdekse
- Ytre deksel |
| (3) - Tagential mini aktivator
- Tagential mini aktivator | (6) - Innerkabinett
- Indre kabinett | (9) - Höjjustering 6-8 cm.
- Høydejustering 6-8 cm. |



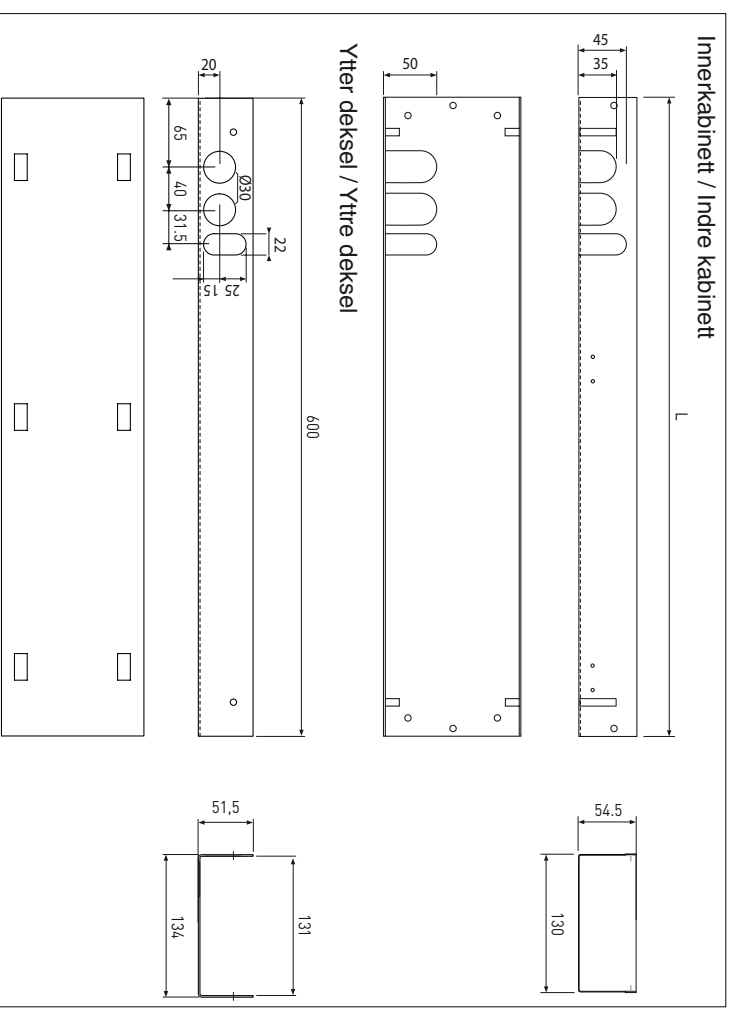

Dimensioner / Dimensioner



model	60	95	130	165	200
L (cm)	60	95	130	165	200

- Hydraulisk och elektrisk tillkoppling är standard plasserat på venstre side, Hydraulisk kobling=1/2",
Hydraulisk kobling=1/2"

- Hydraulisk og elektrisk tilkobling er standard plassert på venstre side, Hydraulisk kobling=1/2"

Deler	Modell: 60	95	130	165	200
	4	6	8	10	12
	6	8	10	12	14
	2	2	2	2	2
	6	6	6	6	6



Viktig



Höjdjustering / Høydejustering

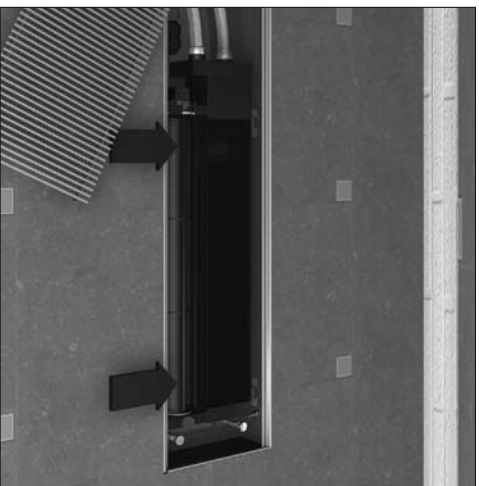

Installera enheten med värmvekslaren mot vägg.

Installer enheten med värmvekslaren mot vägg.

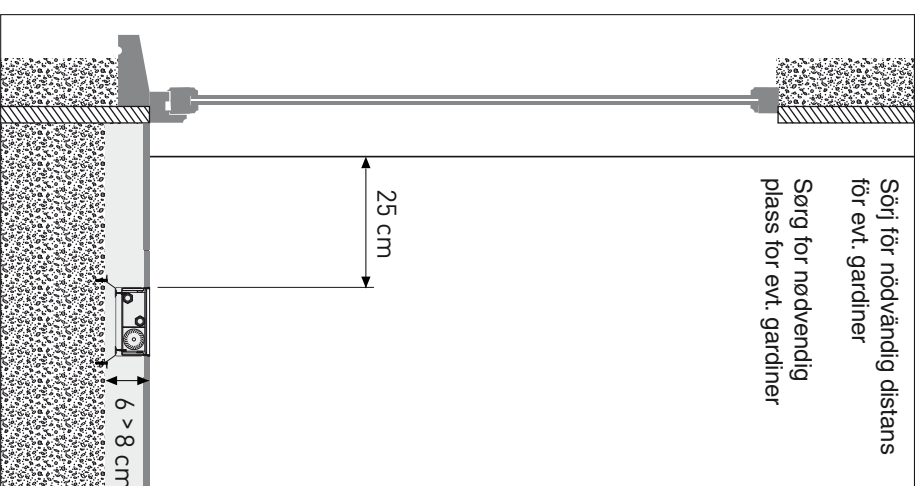

Variabel höjd / Variabel høyde min. 6 cm >< max/maks 8 cm

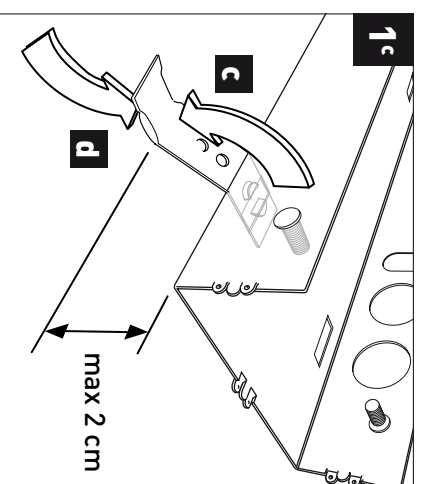
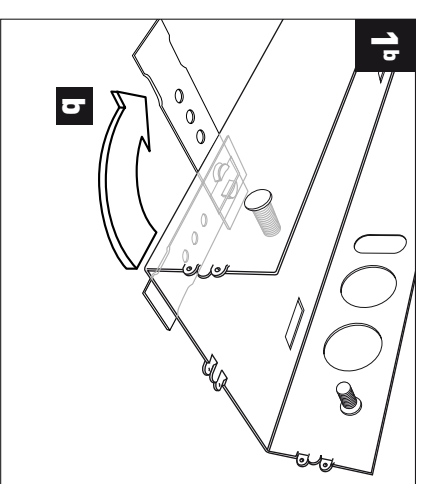
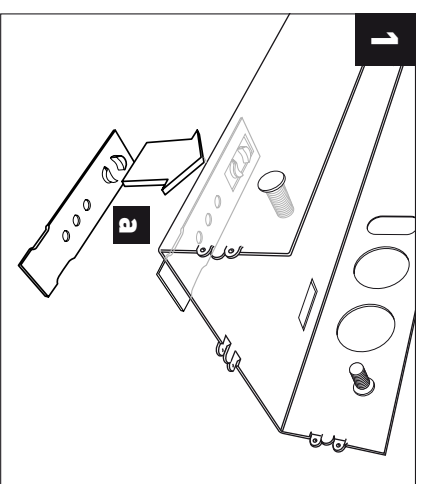
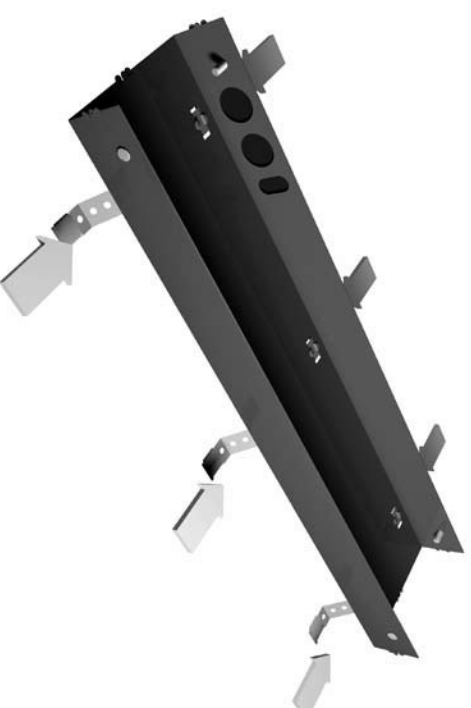
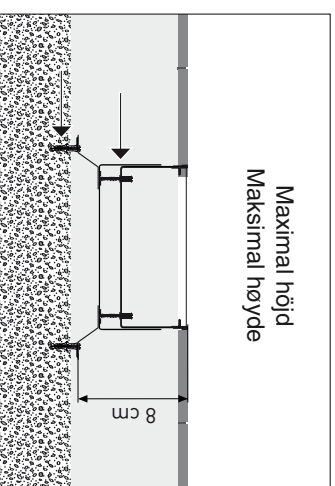
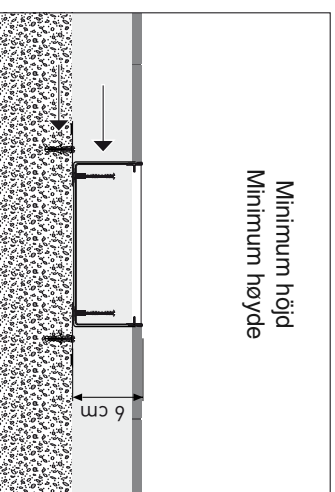

Höjdjusteringsblekk svinges ut och böjas till rätt vinkel för Micro Canal önskat höjd för ferdig gulv.

Höjdejusteringsblekk svinges ut og bøyes til den vinkel som gir Micro Canal høyde med ferdig gulv.

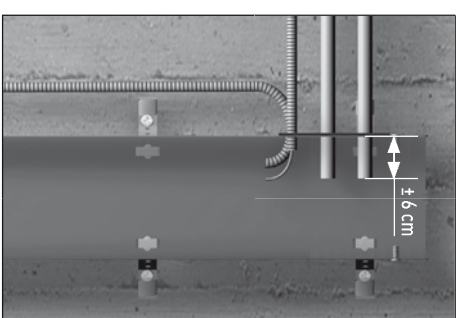
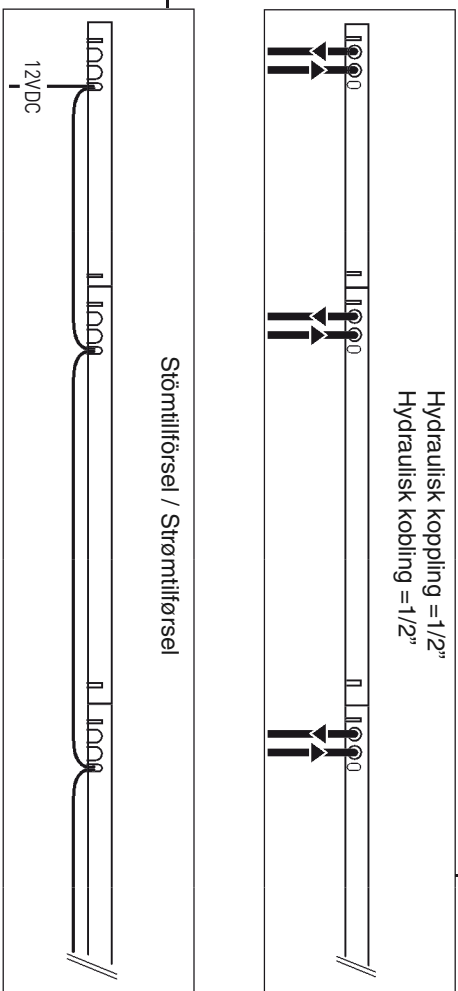
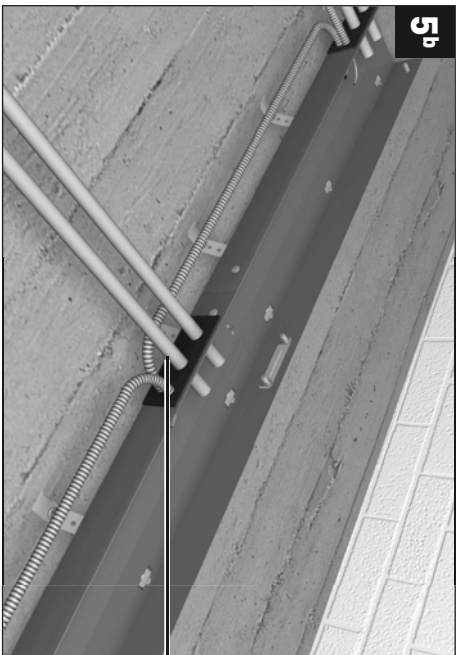
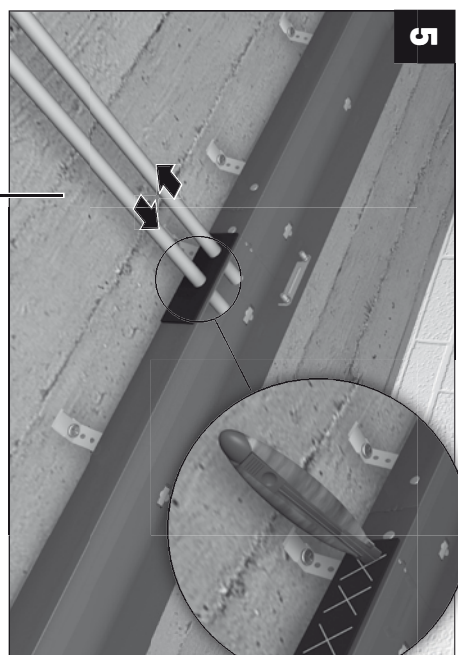
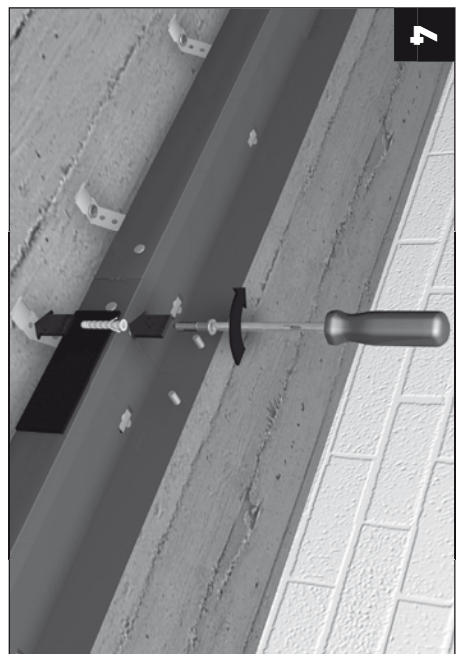
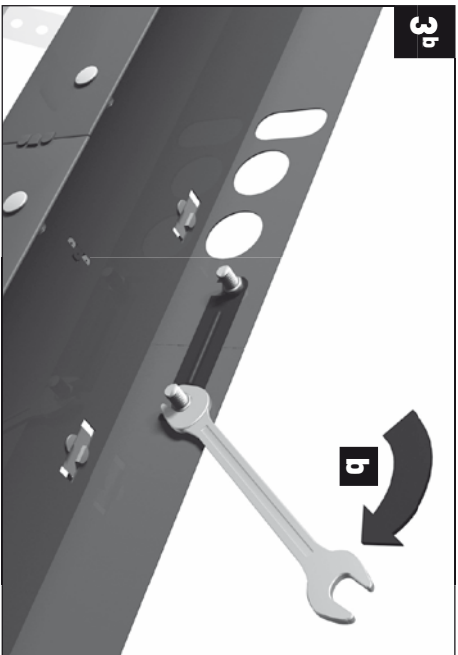
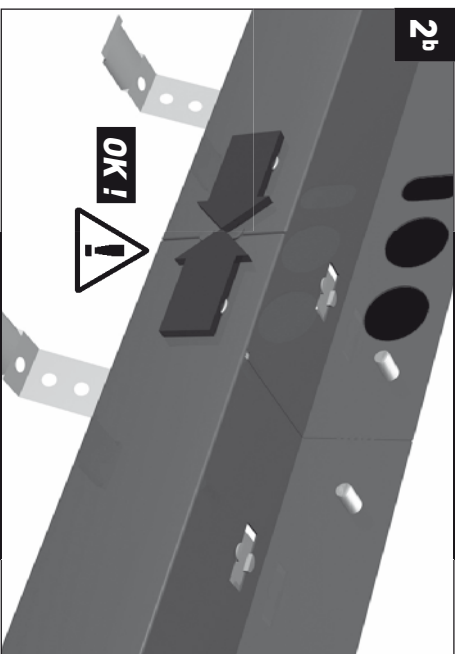
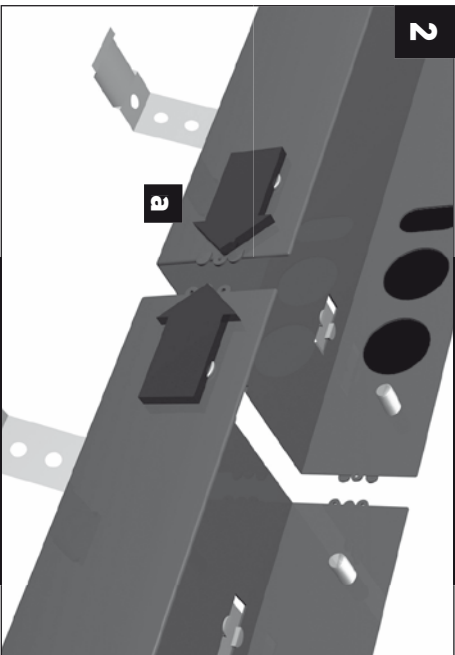

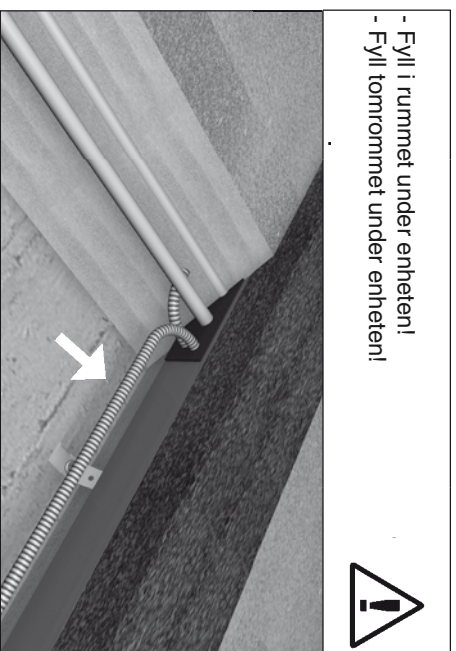

- Fyll i rummet under enheten!
- Fyll tomrummet under enheten!

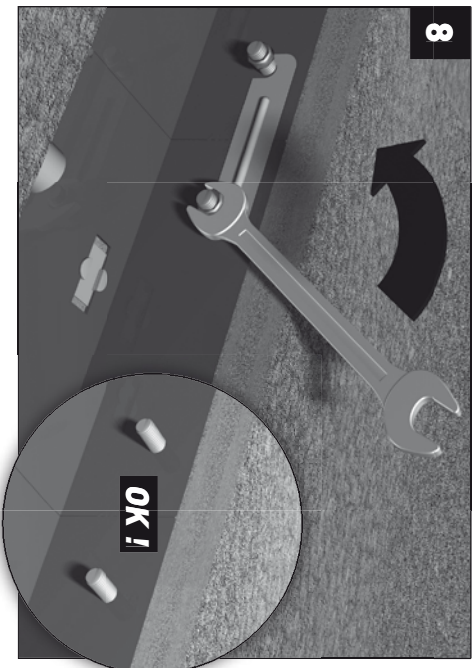
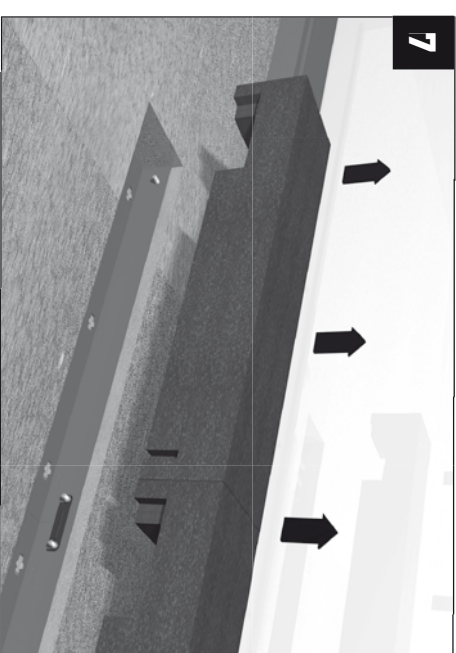

- Ferdigställ golvet för det indre kabinettet monteras.
- Ferdigställ golvet för det indre kabinettet monteras.

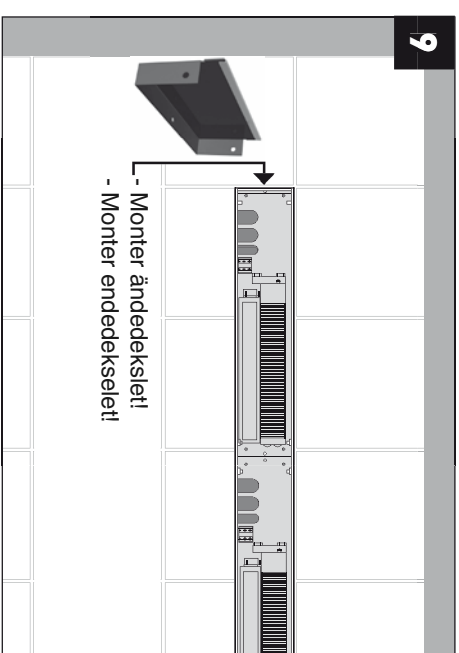

- Monter änddedekslet!
- Monter änddedekslet!

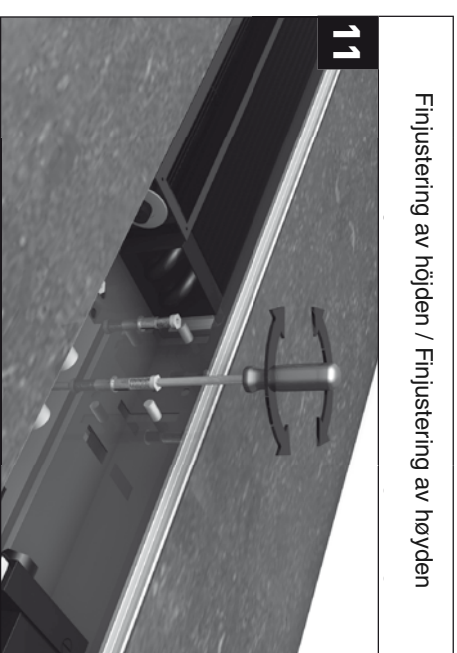
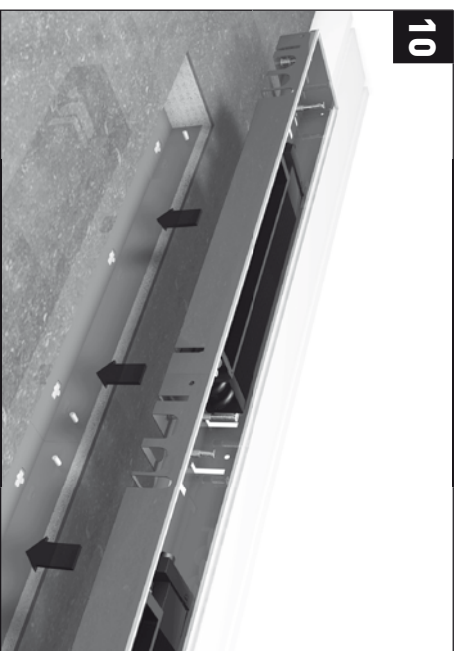

Finjustering av höjden / Finjustering av höjden

11

12

L60: Förankringa av det inre kabinettet / Forankring av den indre kabinettet

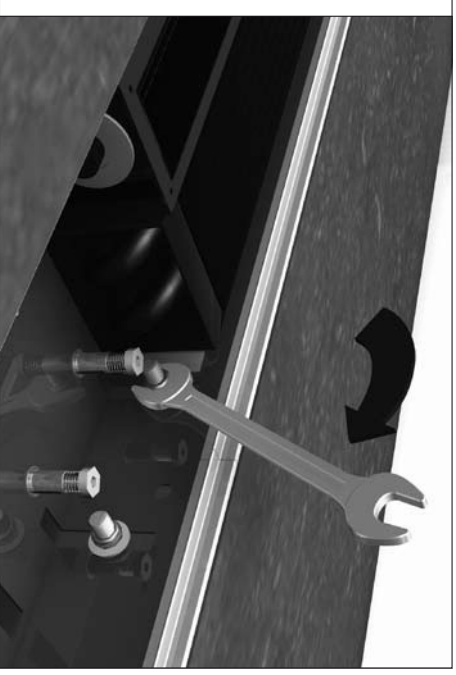

12b

L 90 / 130 / 165 / 200: Förankringa av det inre kabinettet / Forankring av den indre kabinettet

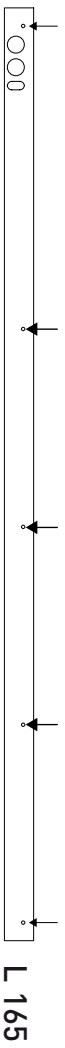
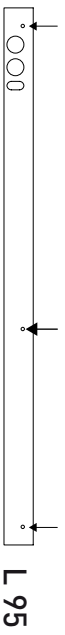

För montering av det inre kabinettet, lyft ur värmväxslaren.

För montering av det indre kabinettet, fjern varmeväxslaren midlertidig.

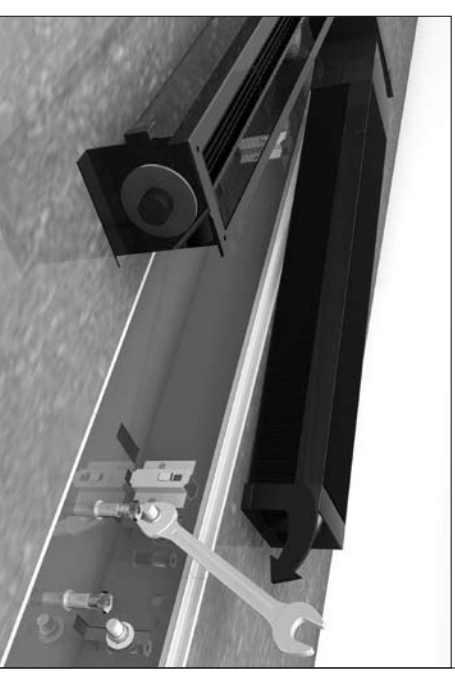
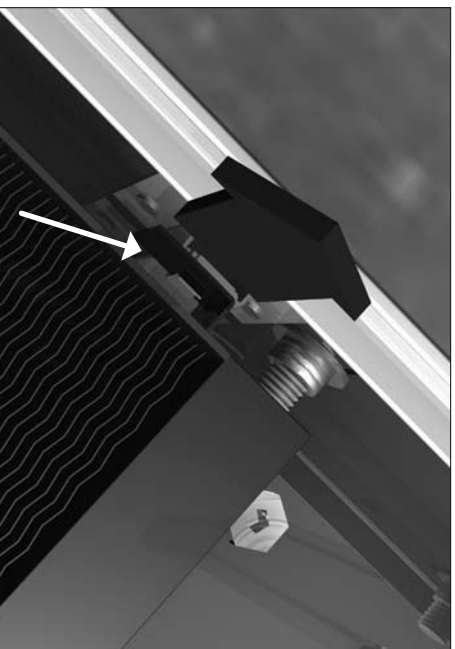

13

Vår Uppmerksom på att vattentemperatur-sensoren är
 plassert n re varmeveksleren.
 Vattentemperaturen m ste v ra min. 30 C

V er oppmerksom p  at vanntemperatur sensoren  r
 plassert n r varmeveksleren.
 Vanntemperaturen m  v re min. 30 C

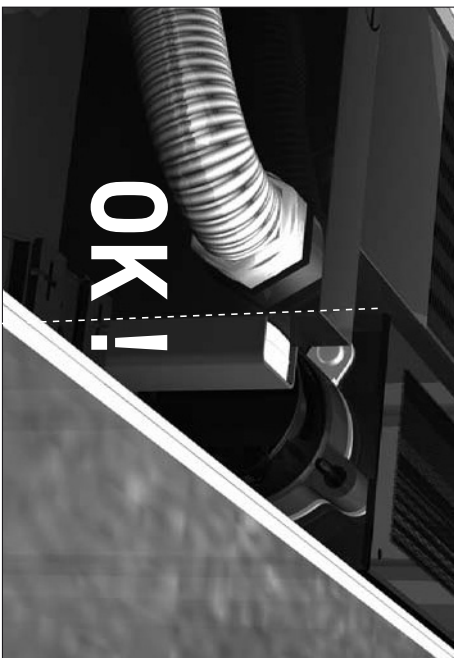
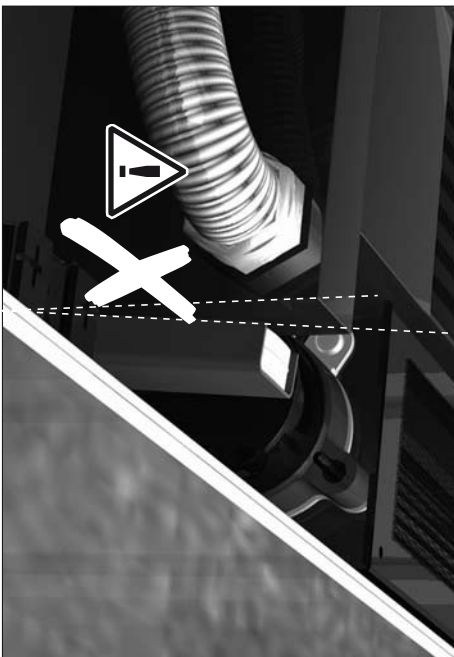
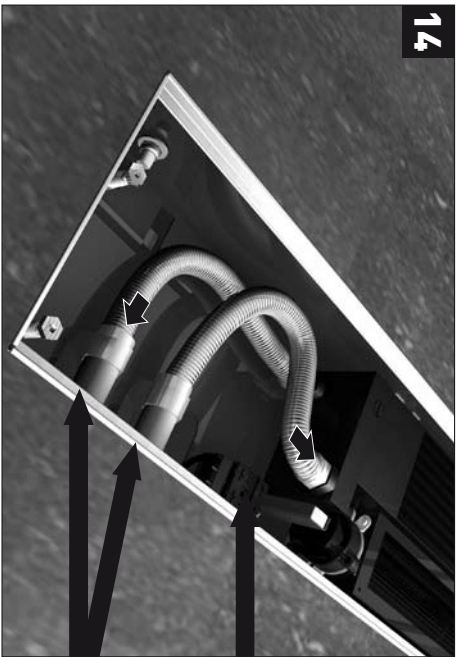
**14**

- Elektrisk tilkoppling

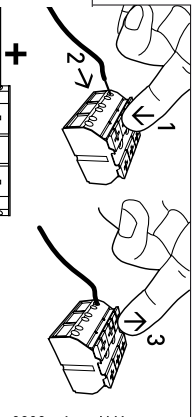

- Elektrisk tilkobling

- Hudraulisk tilkoppling, anv nd Teflon eller flax
 - Hudraulisk tilkobling, bruk Teflon eller flax

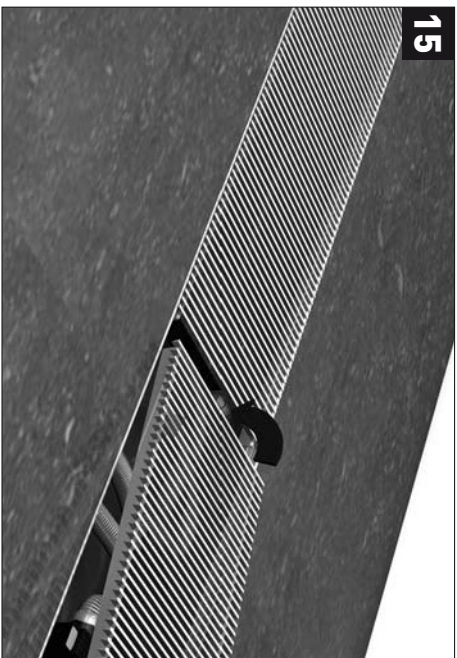
15

Principskiss for 2-veis kontrollventil / Prinsip skema for 2-veis kontrollventil

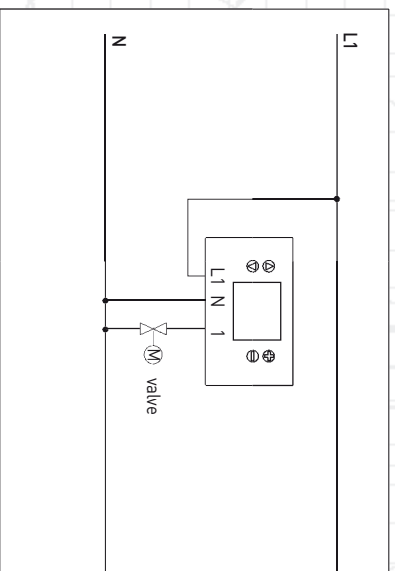

- L1 Strömtilførsel termostat.
Strömtilførsel termostat
- N Nøytral /Nøytral
- Q1 Potensial fri kontakt varme
Potensial fri kontakt varme

Principskiss for tilkoppling / Prinsip skema for tilkoppling

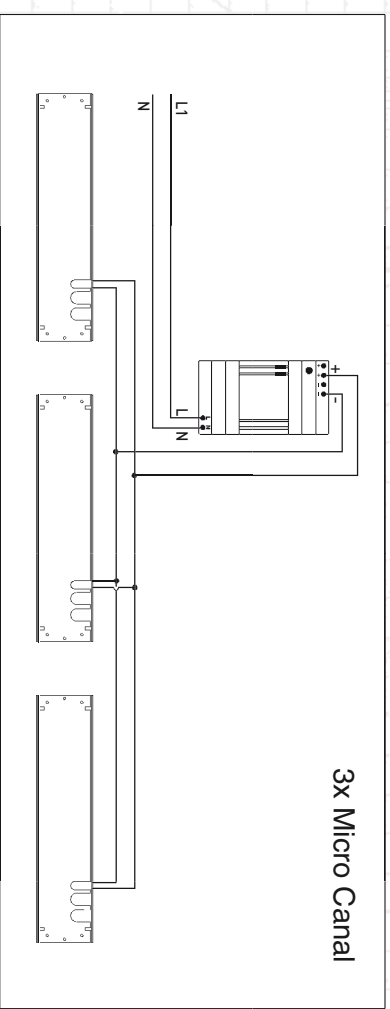

Maximal kabellængd releatert till antal motorer (max spänningstap 5%)
Maksimal kabellængde releatert til antal motorer (maks spennningstap 5%)

motors / moteurs	5	10	15	20	25	30	35	40	45	50
2.5 mm ²	171	86	57	43	34	29	24	21	19	17
1.5 mm ²	103	51	34	26	21	17	15	13	11	10
1.0 mm ²	69	34	23	17	14	11	10	9	8	7
0.75 mm ²	51	26	17	13	10	9	7	6	6	5
0.5 mm ²	34	17	11	9	7	6	5	4	4	3

Dimensjoner i meter / Dimensjoner i meter

www.epecon.se

EPECON

Epecon AB, Florettgatan 22 A,
SE-254 67 Helsingborg.
Telefon 042-25 01 40, Telefax 042-25 01 30
[www.epecon.se](mailto:info@epecon.se)

Oslo

Oksenøyveien 12, 1366 Lysaker
Tlf 67 10 25 00 - Fax 67 10 24 99

Trondheim

Travbanaveien 1, 7044 Trondheim
Tlf 73 84 74 00 - Fax 73 84 74 01

Bergen

Liamyrane 6, 5132 Nyborg
Tlf 55 39 39 45 - Fax 55 39 39 41

www.lyngson.no

LYNGSON