



B16

COMPACT BRAZED HEAT EXCHANGER

Experience the true original: the B-type

The B16 has been specially designed for one-phase applications, and is tailored to cover the capacities and specifications of district heating sub-stations, radiator circuits and tap water heating applications over a wide capacity range. The B16 is also optimal for oil cooling.

Easy to choose the right product solution

With SWEP's unique SSP CBE, the SWEP Software Package, you can do advanced heat transfer calculations yourself, and choose the product solution that suits your application best. It's also easy to choose connections and generate drawings of the complete product. If you would like advice, or you would like to discuss different product solutions, SWEP offers all the service and support your need.

THIRD-PARTY APPROVALS (selection)

Europe, Pressure Equipment Directive (PED 97/23/EC)

For additional information please contact your local SWEP representative. SWEP reserves the right to make changes without prior notice.

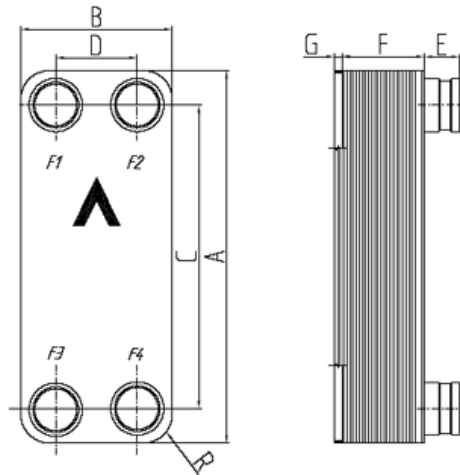

Measurements(mm)		Tolerance
A	376	+2 /-2
B	119	+1 /-1
C	320	+1 /-1
D	63	+1 /-1
E	27.1 (opt. 45.1)	+1 /-1
F	4+2.24xNP	+0.5% /-1.5%
G	6	+1 /-1
R	23	

Port size F/P: 33mm

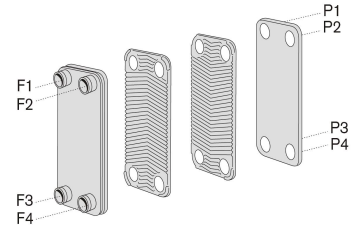

CBE port denomination

STANDARD CONNECTIONS

For specific dimensions, or information about other types of connections, please contact your SWEP sales representative.



Externally Threaded Connections (Male)

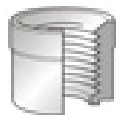

Internally Threaded Connections (Female) of Standard Type



Soldering Connections (Sweat Connections)



Internally Threaded Connections (Female) with a Hexagonal Exterior

TECHNICAL DATA

Max working pressure at 155°C	Inner circuit: 31 bar (450psi) Outer circuit: 31 bar (450psi)
Max working pressure at 225°C	Inner circuit: 27 bar (392psi) Outer circuit: 27 bar (392psi)
Test pressure:	45 bar (653psi)
Min temperature:	-196°C (-321F)
Max temperature:	225°C (437F)
Max number of plates (NoP)	140
CBE weight	1.5+NoPx0.114kg (3.3+NoPx0.3lbs)
Hold-up volume: inner circuit	(NoP/2-1)x0.082 litres ((NoP/2-1)x0.003 gal.)
Plate material:	Parts in contact with fluid: EN 10028/7-1.4401 (AISI 316) Parts not in contact with fluid: EN 10028/7-1.4301 (AISI 304)
Brazing material:	Pure Copper
Connection material	EN 10272-1.4401 (AISI 316)

CAPACITY GRAPH

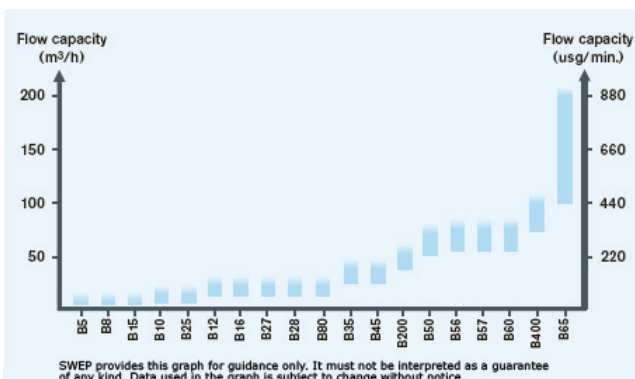

SWEP INTERNATIONAL AB

Box 105, SE-261 22 Landskrona, Sweden
Phone +46 418 40 04 00
Fax +46 418 292 95
Internet: www.swep.net
E-mail: info@swep.net