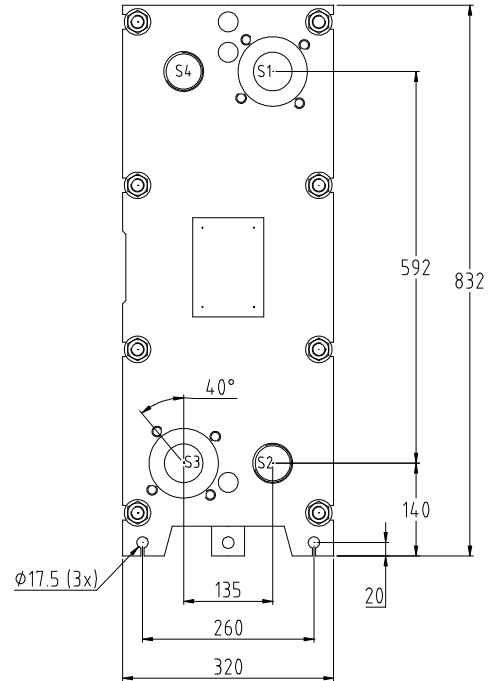
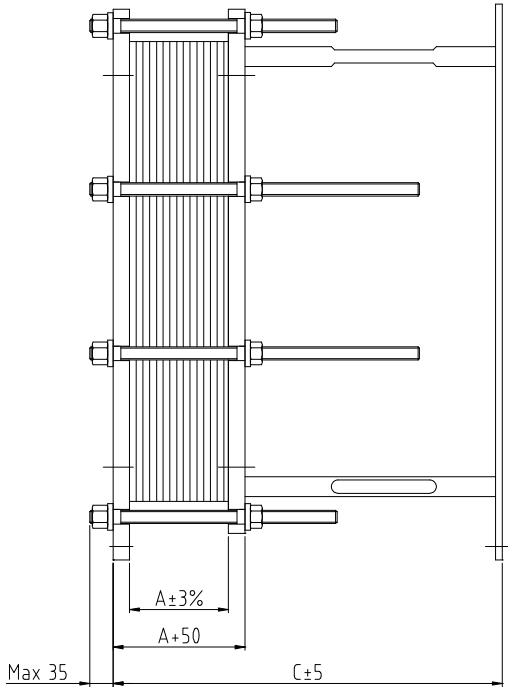



PLATE HEAT EXCHANGER **GL-13P**
DIMENSIONS MM



Available connections:

- 4x flange connections
- 4x threaded pipe connections
- 2x flange connections / 2x pipe connections

The Plate Heat Exchanger has 4 connections as standard and should be installed with min. 600 mm space on both sides for service work.

Subject to alterations without prior notice.

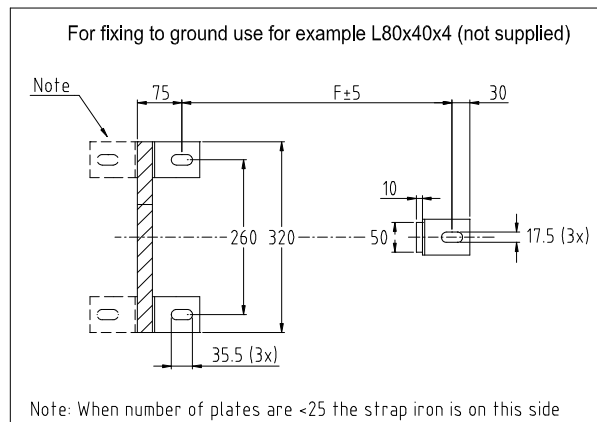
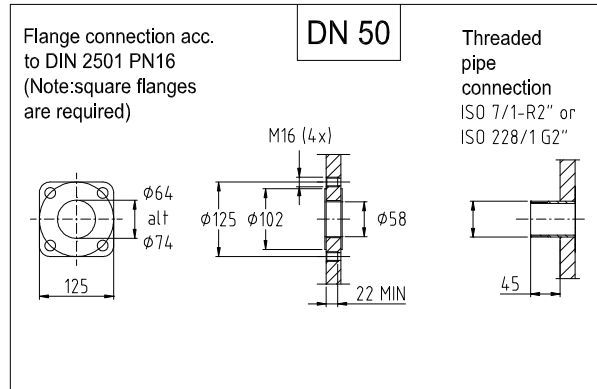
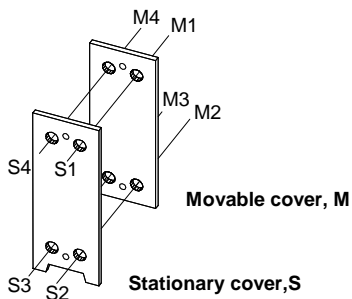



PLATE HEAT EXCHANGER **GL-**
13P
DIMENSIONS MM

Standard connection dimension	DN50								
Tightening bolt	M20								
No. of long tightening bolts (T _L)	4								
No. of short tightening bolts (T _S)	4								
Cover thickness	25 mm								
Weight of guiding bar	1,4 kg/m								
Weight of tightening bolt	2,0 kg/m								
A-dimension	3,4*n mm								
C-dimension	LG								
F-dimension	LG – 25 mm								
Weight plate+gasket (W)	<table style="display: inline-table; border: none;"> <tr> <td>AISI 304/316 0,5 mm</td> <td>0,76 kg</td> </tr> <tr> <td>AISI 304/316 0,6 mm</td> <td>0,91 kg</td> </tr> <tr> <td>Titanium 0,5 mm</td> <td>0,46 kg</td> </tr> <tr> <td>Titanium 0,6 mm</td> <td>0,55 kg</td> </tr> </table>	AISI 304/316 0,5 mm	0,76 kg	AISI 304/316 0,6 mm	0,91 kg	Titanium 0,5 mm	0,46 kg	Titanium 0,6 mm	0,55 kg
AISI 304/316 0,5 mm	0,76 kg								
AISI 304/316 0,6 mm	0,91 kg								
Titanium 0,5 mm	0,46 kg								
Titanium 0,6 mm	0,55 kg								
Weight Frame	110+n*W kg								

Max No of plates	LT _L	LG	C	F
71	500	590	590	565
115	750	840	840	815
159	1000	1090	1090 ¹⁾	1065

LT_L = Length long tightning bolt
 LG = Length guiding bar
 n = number of plates

1) C > 840 mm use floor support

Total max no. of plates	
AISI 304/316 0,5 mm	159

All data is based on plates with material AISI 304/316 and thickness 0,5 mm.