

General information

Solenoid valves series 2N are universal direct solenoid valves, requiring no differential pressure between the input and the output. Depending on the type of used diaphragm (NBR, EPDM, FPM (Viton)), 2N solenoid valves can be used to control the flow of a wide range of factors. Thanks to its simple construction, the solenoid valve is trouble-free and durable, and the service is quick and easy.

Technical parameters

Model	Diaphragm material	Orifice	Flow KV	Thread	Working pressure	Coil power		Coil voltage		Body material
						DC [W]	AC [VA]	DC	AC	
2N NC - normalnie zamknięty/normally close										
2N08	H *	2,5	0,19	1/4	0-10	13	18	12, 24	24, 42, 230	Brass, ss304
2N10	H *	10	2	3/8	0,1-16	13	18	12, 24	24, 42, 230	Brass
2N10	H *	10	2	1/2	0,1-16	13	18	12, 24	24, 42, 230	Brass
2N15-M	N/H *	15	3,98	3/8	0-10	31	26	12, 24	24, 42, 110, 230	Brass, ss304
2N15-M	H *	15	3,98	1/2	0-10	31	26	12, 24	24, 42, 110, 230	ss304
2N15	N/E/H *	16	4	1/2	0-10	31	26	12, 24	24, 42, 110, 230	Brass, ss304
2N20	N/E/H *	20	7,25	3/4	0-10	31	26	12, 24	24, 42, 110, 230	Brass, ss304
2N25	N/E/H *	25	10	1	0-10	31	26	12, 24	24, 42, 110, 230	Brass, ss304
2N32-M	N/E/H *	30	17,2	1 1/4	0-10	31	26	12, 24	24, 42, 110, 230	Brass, ss304
2N32	N/E/H *	32	20,6	1 1/4	0-10	38	28	12, 24	24, 230	Brass, ss304
2N40	N/E/H *	40	24,2	1 1/2	0-10	38	28	12, 24	24, 230	Brass, ss304
2N50-M	N/E/H *	50	30	2	0-10	38	28	12, 24	24, 230	Brass, ss304
2N50	N/E/H *	50	40	2	0-10	38	28	12, 24	24, 230	Brass, ss304
2N NO - normalnie otwarte/normally open										
2N10NO	N *	4	0,51	3/8	0-10	31	26	12, 24	24, 42, 110, 230	Brass
2N15NO	N/E/H *	16	4	1/2	0-8	31	26	12, 24	24, 42, 110, 230	Brass, ss304
2N20NO	N/E/H *	20	7,25	3/4	0-8	31	26	12, 24	24, 42, 110, 230	Brass, ss304
2N25NO	N/E/H *	25	10	1	0-8	31	26	12, 24	24, 42, 110, 230	Brass, ss304
2N32-M NO	N/E/H *	32	17,2	1 1/4	0-8	31	26	12, 24	24, 42, 110, 230	Brass, ss304
2N32NO	N/E/H *	32	20,6	1 1/4	0-10	38	28	12, 24	24, 230	Brass, ss304
2N40NO	N/E/H *	40	24,2	1 1/2	0-10	38	28	12, 24	24, 230	Brass, ss304
2N50-M NO	N/E/H *	50	30	2	0-10	38	28	12, 24	24, 230	Brass, ss304
2N50NO	N/E/H *	50	40	2	0-10	38	28	12, 24	24, 230	Brass, ss304

* N - NBR -10 to 90 °C - water, air, gas, light oil
 E - EPDM -20 to 130 °C - hot water, liquids, steam
 H - FPM (Viton) 10 to 150 °C high chemical resistance

Dimensions

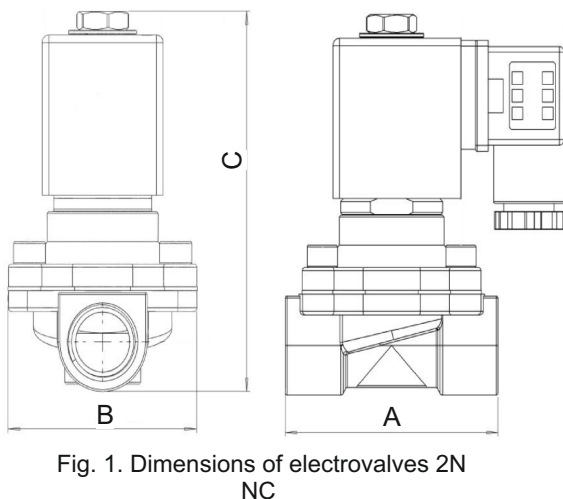

Fig. 1. Dimensions of electrovalves 2N NC

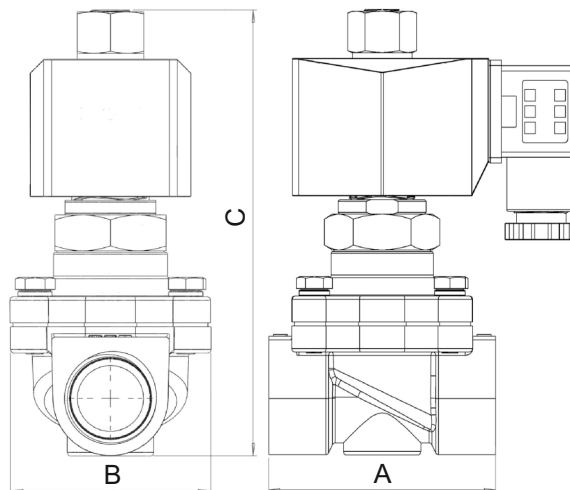

Fig. 2. Dimensions of electrovalves 2N NO

	A	B	C
2N08	40,5	30	75
2N10	62	32,5	79,4
2N15	67	54	106
2N20	73	55	117
2N25	99	78	125
2N32-M	95	80	130
2N32	116	84	131
2N40	116	93	168
2N50-M	137	94	180
2N50	172	124	195
2N10-NO	70	56	122
2N15-NO	70	56	122
2N20-NO	72	56	127
2N25-NO	100	77	137
2N32-M-NO	97	80	145
2N32-NO	114	85	176
2N40-NO	123	91	184
2N50-M-NO	137	94	191
2N50-NO	170	117	203

Set contains

- valve
- coil with DIN plug and LED

Electrical connection

1. Unscrew and remove the screw from the plastic housing and unplug from the coil.
2. Use the removed screw to push the terminal block out of the plastic housing.

3. Terminal block have three places to connect electrical wire with symbols "1", "2" and ground " ".

- for DC coil, connect to "1" your positive „+" wire and to "2" your negative "-" wire.
- for AC coil to "1" connect phase wire, to "2" connect neutral lead, and to " " ground wire.

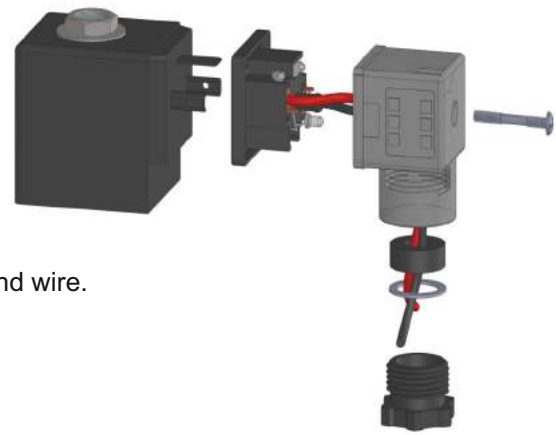

Fig. 3. Electrical connection of coil

Installation and operation

1. Connect the inlet and outlet to the valve ports according to the flow direction arrow marked on valve body (see fig. 4). Joints should be sealed accordingly.
2. Put and screw the coil on to the armature tube of the valve. **Attention!!! Do not energize the coil without installing it onto the valve or connect the coil to a different voltage than specified. This will burn the coil and could create fire hazards.**
3. Standard valves are supplied with continuous duty coils. Parameters of coil you can find on sticker on the coil body. The coil temperature may rise significantly (up to 90°C) if energized for extended periods - this is normal. To limit coil heating and power consumption the power save device can be used. Coil has protection rating IP65.

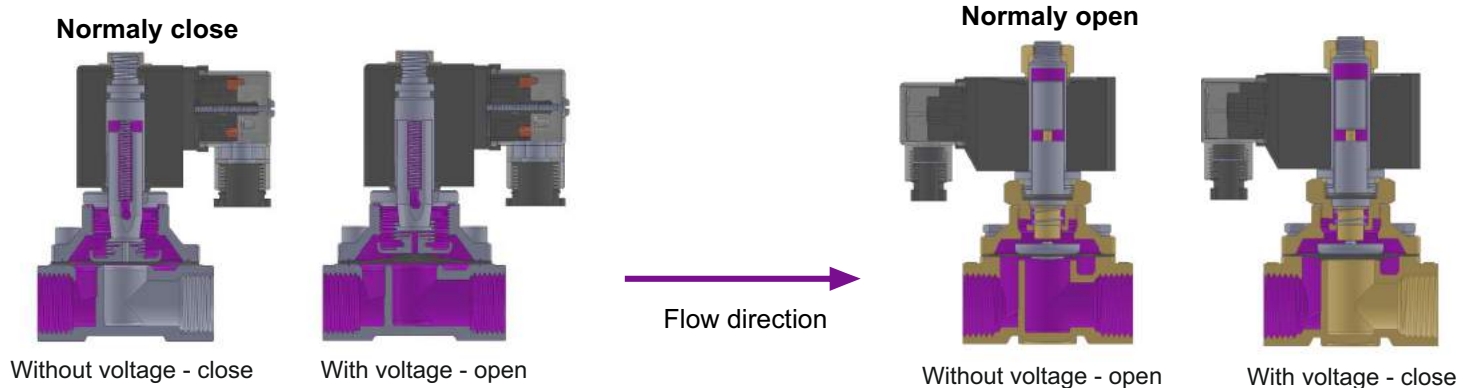

Fig. 4. Flow direction

Construction of electrovalves

